

Modeling of PV Based Distributed Generator Systems with Diverse Load Patterns

Mehmet H. Cintuglu, mcint015@fiu.edu, Armando Altamirano, araltami@fiu.edu

Osama A. Mohammed, mohammed@fiu.edu

Energy Systems Research Laboratory, ECE Department
Florida International University
Miami, USA

ABSTRACT

Solar based distributed generators are the most promising renewable energy technology in low voltage grid networks. Distributed generators are installed to supply local customer load demand as main purpose with a permanent percent power level of connected transformer. Load patterns show variation according to location and utilization habit of the customers such as residential, industrial, agricultural watering purpose. As a result of different load profiles, generated power and the local load demand might not match depending on the pattern. If injected power from distributed generators to the grid exceeds connected customer local load, this will result reverse power flow into MV level, which is generally forbidden situation since it introduces unexpected voltage variations and unreliable generation forecast. In order to avoid reverse power flow, the injected power to the grid by distributed generators should be controlled locally. In this paper we studied injected power control scheme to avoid reverse power flow in a part of generic Turkish distribution network consisting of MV line equivalent model, transformer, LV loads and inverter based distributed generator systems with proper protection and specifications comply with local regulatory rules and IEEE 1547 standards. Proposed reverse power flow controller method was performed based on digital computer simulation approach by using Matlab/Simulink software package.

Keywords- distributed generator, solar energy, power flow

1. INTRODUCTION

In last decade, with the idea of penetration of distributed generators into existing grid, electricity network has been facing a deep change that never happened before from invention of the electricity. Distributed generators can provide many benefits including reduced distribution costs, flexible operation and enhanced reliability. Local generation can reduce the energy losses and delay required infrastructure investment for transmission and distribution lines. However, besides many benefits of distributed generators, implementation of this systems can be quite complex into the existing grid networks. Voltage regulatory problems, voltage flickers, reverse power flow and islanding are major problems related to distributed resources.

Basically, electricity network structured with one way power flow: generation, transmission and distribution. However with penetration of distributed generators, this one way power flow rule will be no longer valid. In contrast to conventional generation structure, distributed generator enables electricity generation locally – mostly very close to dedicated loads. Once feeding the local load demand, exceeding power will be transfer to infinite electricity grid. In that sense, power flow direction will change. This conflict and unpredicted situation would result operation problems inside the grid. Inside the LV feeder zone, reverse power flow might be tolerated. However, flow exchange from distribution layers like LV to

MV and MV to HV would result congestion and complicated network profile.

Grid connected distributed resources are mostly used for peak shaving and local load demands. According to IEEE 1547 standards [1], they do not contribute voltage or frequency control regulation. Moreover, they need to operate at unity power factor or a range between 0.95 leading – lagging. Active power contribution is basically the only requirement of distributed generator plants. Apart from other complexities, even only active power injection from remote distributed generator systems is enough to create unexpected power flows in existing conventional grid structure. Therefore regulations limit the distributed generator connection power to each transformer by allocable capacity. Table 1 shows allocable capacity rating in Turkish electricity grid. However, this limitation will not be enough to prevent from reverse power flow in some load patterns.

Table 1. Allocable capacity for DG

Transformer Capacity (kVA)	Allocable Capacity For DG (kW)	Allocable Capacity for Each Individual (kW)
Demand < 100	Demand x 0.3	7.5
100 < Demand < 1000		Demand x 0.1
Demand > 1000		100 kW

SCADA systems may not be available in far terminals to control remotely. Control of the generated power from distributed resource should be carried out locally and automatically with proper power management intelligence, since it is not possible to deploy a technician or an engineer responsible for operation to each generation unit. So far, many researches have been done regarding prevention of reverse power flow. Battery storage and heat pump water heaters [2-4] were proposed to use the opportunity of additional power when generation exceeds demand. Battery storage is a promising way to store energy however heat pump water heaters may not be necessary in distributed generator systems which are connected to illumination and agricultural watering transformers. Furthermore, optimal sizing and location of a PV system was proposed in MV distribution feeders [5] to avoid reverse power flow along the feeder.

The objective of this paper to present appropriate power control scheme in order to avoid reverse power flow from LV to MV by controlling inverter based distributed generator power output considering different load profile feeders. Section 2 deals with the load pattern analysis for various type utilization purposes. Section 3 analyzes typical distribution architecture in Turkish electricity network grid transformer model in rural area supplying local loads and comprising solar based distributed generators connected to MV feeder. Section 4 introduces simulation system of the proposed model. Conclusions are stated in Section 5.

2. LOAD PROFILES OF DIFFERENT FEEDER PURPOSES

In power networks, different feeders exist in terms of load pattern according to the utilization purpose. Load demands might show variation according to their customer behavior. Load profiles are mainly divided into five different categories: Industrial, commercial, residential, agricultural watering and illumination. Following figures show actual load profile data collected from a utility zone in a city from Turkey depending on customer behavior [6]. If we will assume each of the profile connected to a 50 kVA transformer, demanded actual load also could be available.

2.1. Industrial Load Profile

Industrial load profile has the most uniform distribution among the load profiles during the day. Utilization decreases between 18-22 hours, this is because to balance residential peak hours. Figure 1(a)-(b) shows the distribution of demand in 24 hours for weekdays and weekends.

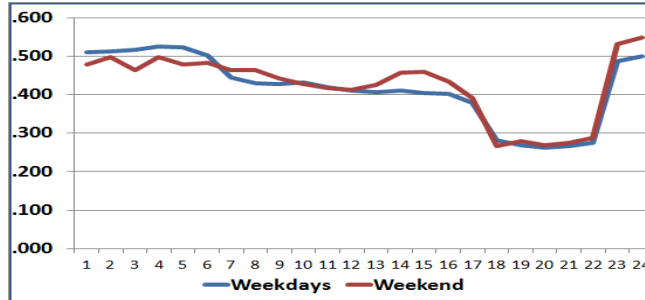

Figure. 1(a). Capacity factor for industrial load profile

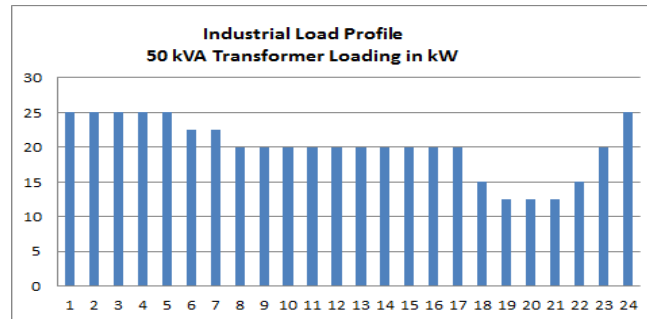

Figure. 1(b). Demand as per 50 kVA transformer for industrial load profile

According to regulations, the maximum allocated generation capacity to 50 kVA transformer is limited to 15 kW. In this load pattern generation never exceeds load demand. In this case, 0.3 capacity factor for connection of distributed generator units is feasible.

2.2. Commercial Load Profile

Working hours result high peak between 8-21 hours in commercial load pattern customers. This period of time is obviously when solar energy generation is most available. Implementation of distributed generator units on commercial load profile figure 2(a)-(b) will contribute peak shaving significantly. In this case, since solar generation is available mostly from 8 am to 5 pm, 0.3 capacity factor for connection of distributed generator units is feasible.

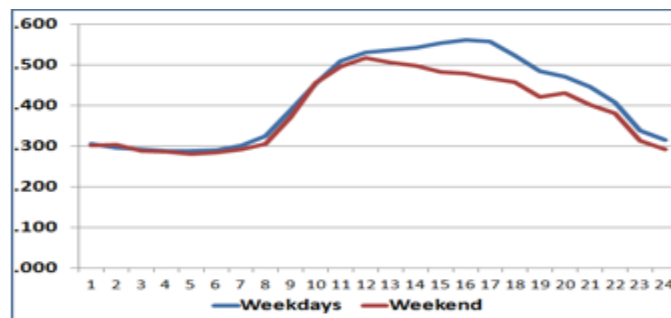

Figure. 2(a). Capacity factor for commercial load profile

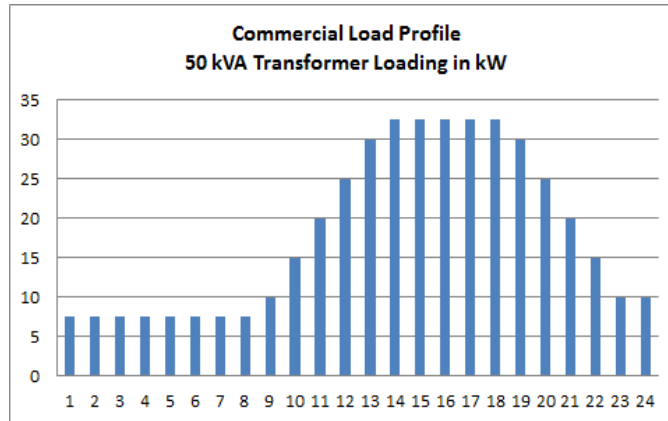

Figure. 2(b). Demand as per 50 kVA transformer for commercial load profile

2.3. Residential Load Profile

Due to permanently running home appliances in residential customers, load profile shows flat demand with exception peak hours noon and evening. Figure 3(a)-(b) apparently shows capacity factor 0.3 is a good approximation.

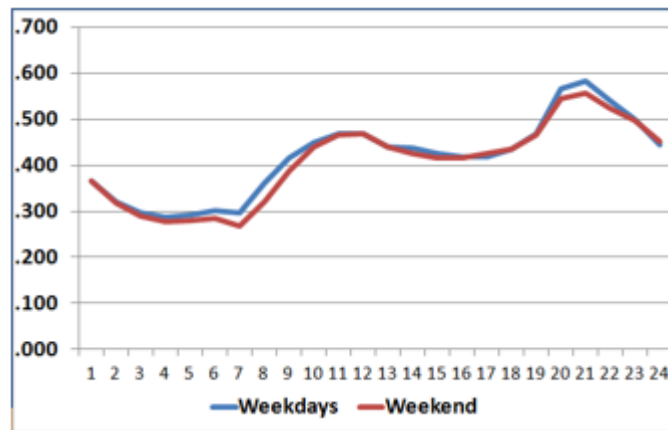

Figure. 3(a). Capacity factor for residential load profile

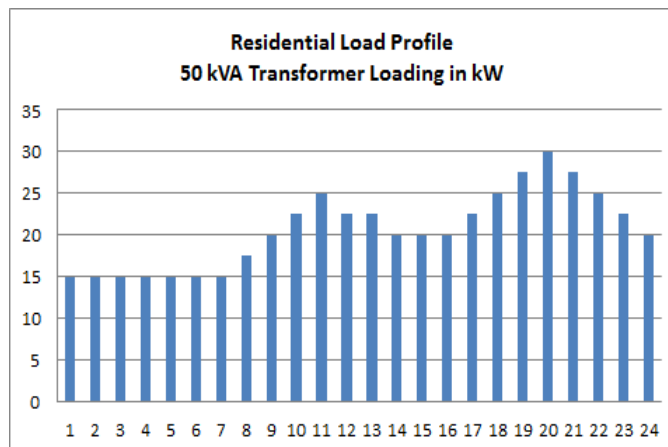

Figure. 3(b). Demand as per 50 kVA transformer for residential load profile

2.4. Agricultural Watering Purpose Load Profile

As seen from figure 4(a)-(b), agricultural watering load profile shows significant variations during the day. Proper implementation of distributed resources would relieve utility supply by mitigation of fluctuation on demand. Since load pattern is quite complex, if inverters will be injecting power to the grid when solar irradiation is most available and presence of no local load, this situation will obviously lead to reverse power flow. Furthermore, many agricultural watering purpose transformers are located in same MV feeder. Many generation plants would cascade and create even a high amount of reverse power flow from MV feeder up to HV/MV substation.

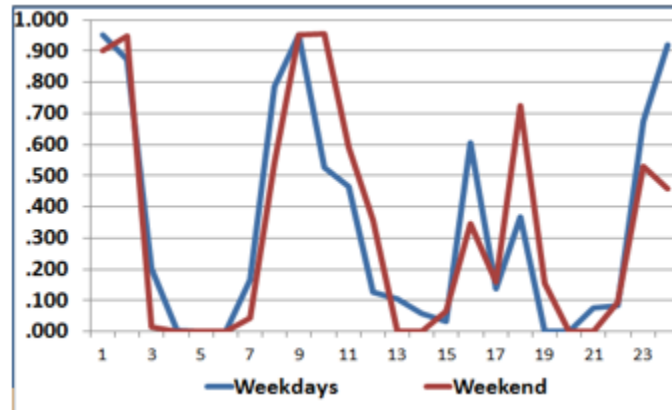

Figure. 4(a). Capacity factor for agricultural load profile

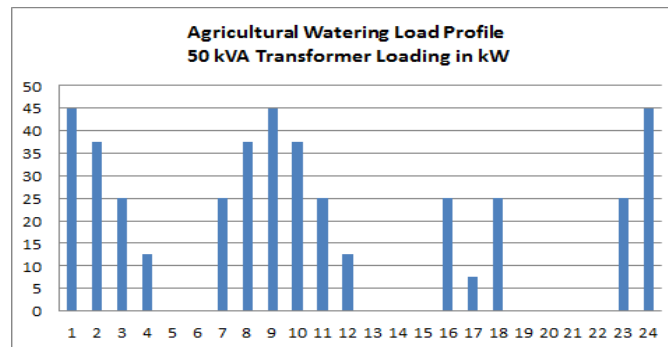

Figure. 4(b). Demand as per 50 kVA transformer for agricultural load profile

2.5. Illumination Load Profile

Illumination purpose transformers are operating almost at zero duty factors during the day. However at night and until early morning, high supply is required due to high demand as seen in figure5 (a)-(b). Charging during the day and using stored energy at night is the most feasible way for illumination purpose feeders. A special control algorithm and necessary storage should be implemented to inverter based distributed resource system.

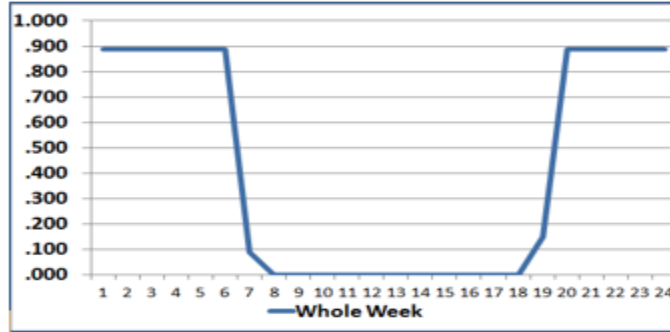

Figure. 5(a). Capacity factor for illumination load profile

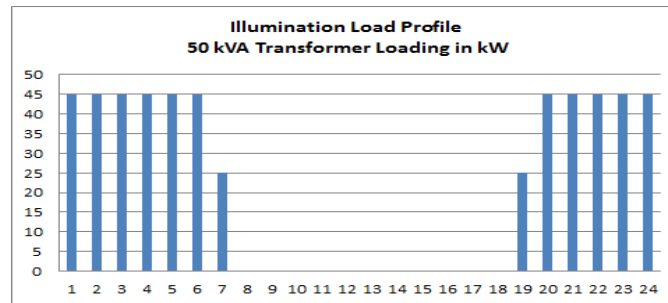

Figure. 5(b). Demand as per 50 kVA transformer for illumination load profile

3. DISTRIBUTION NETWORK STRUCTURE

In this paper, Turkish grid structure and load profiles are taken as reference for study model. MV distribution feeders have 33 kV, 50 Hz operating condition. The studied transformer is 33/0.4 kV 50 kVA standard oil insulating rural type with manual tap changer positions.

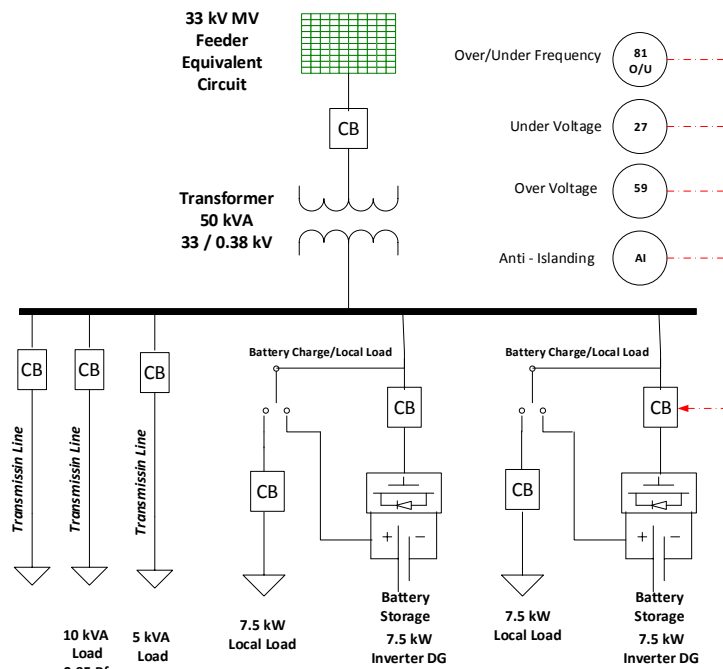

Figure. 6. Transformer and distributed generator model

Rural overhead transmission lines are mostly Swallow or Pigeon conductors. In LV distribution feeders, Aster, Pansy and Rose conductors are widely used. Reactance and resistance values for these conductors are given in Table 2.

Table 2. Transmission line impedance table

Conductor Type	Reactance	Resistance
Aster	-	0.4245 Ω /km
Swallow 3AWG	0.420 Ω /km	1.0742 Ω /km

In our study system, since distribution transformer is 50 kVA rated, according to table 1, we consider two individuals connected 7.5 kW power with total power 15 kW. Remaining capacity is allocated as global load connected to transformer. The inverters can feed either load or charge the battery according to control methodology. Protection model involves over/under voltage, over/under frequency and anti-islanding relays. Since inverters in our model are grid connected, anti-islanding scheme with ROCOF (Rate of change of frequency) detection has been implemented to avoid energizing the islanded area when utility does not exist.

4. SIMULATION OF THE PROPOSED NETWORK AND POWER TRACKING ALGORITHM

Since agricultural watering load pattern requires the most complicated control, in this paper we studied that profile in this paper. However, this control technique should be implemented for each utility feeder with examining the special situation of that kind of feeder. 50 kVA transformers with MV line connection, loads and feeders are modeled in simulation environment.

Two 7.5 kVA, grid connected, hysteresis current controlled inverter based distributed resources, to follow proper current references according to power input references, are modeled in Simulink. Current control method of the inverters is shown in figure 7.

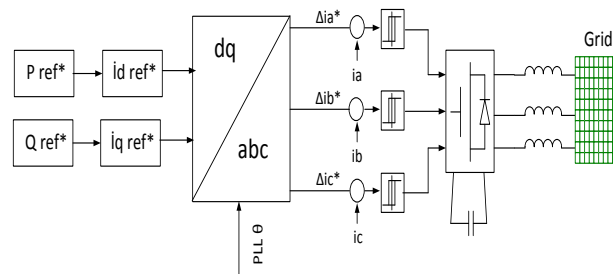

Figure 7. Grid connected hysteresis current controlled inverter control

Figure 8 shows the Simulink expression of study system in figure 6, which consists MV equivalent circuit, transformer, transmission lines, loads, inverters, and protection and control algorithm structures.

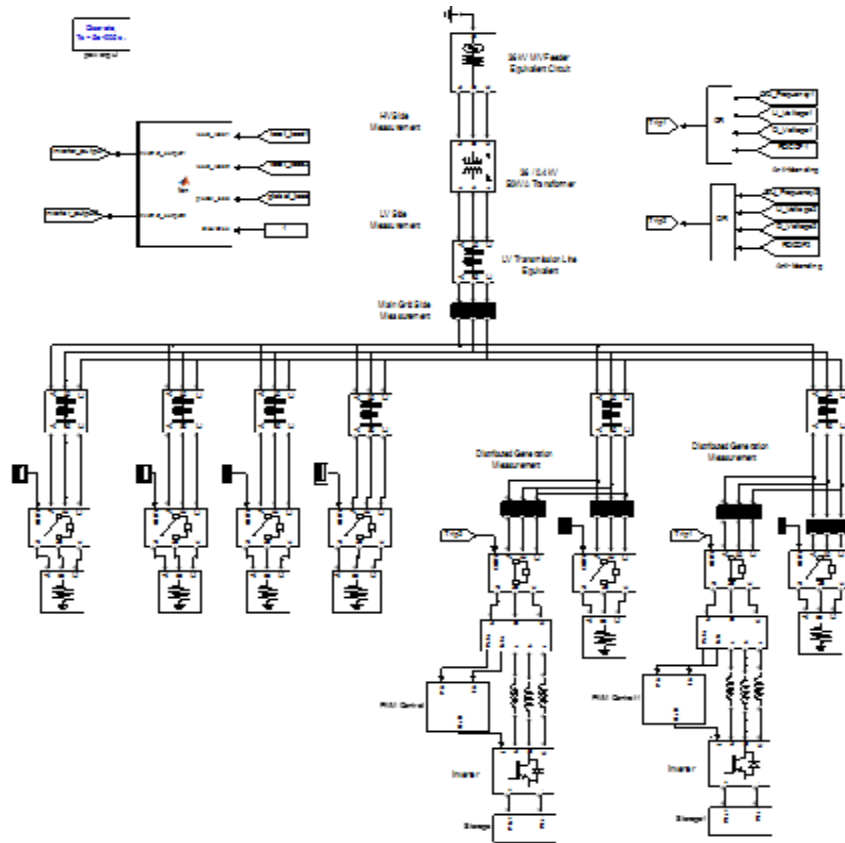

Figure 8. Simulink expression of study system

A very similar load pattern agricultural watering purpose load pattern was constructed by switching the loads in simulation as seen in figure 9 (watts vs. hours of the day). The voltage profile in the main feeder is also in limits.

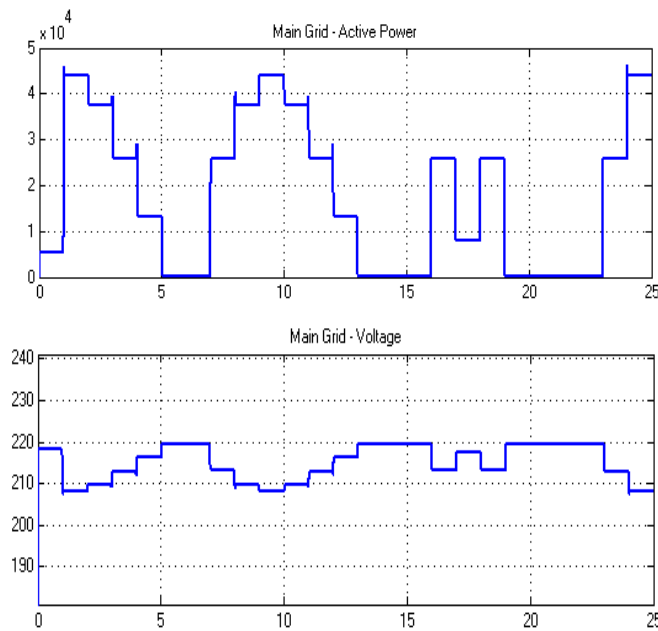

Figure 9. Agricultural watering load pattern

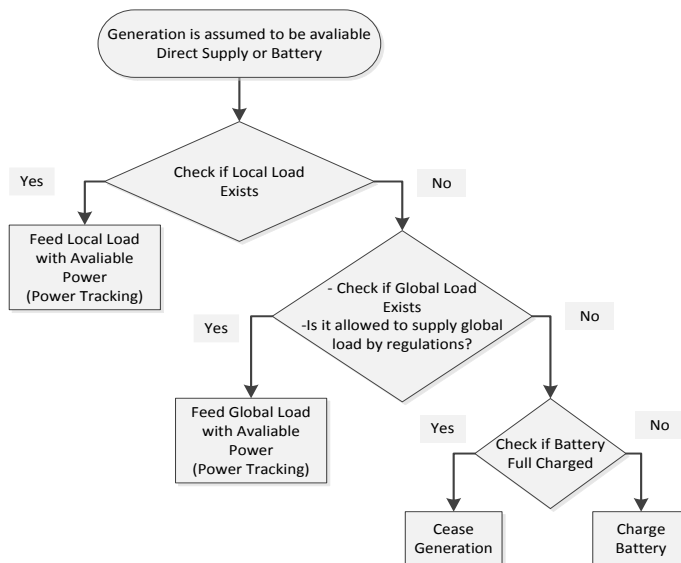

Figure. 10. Flowchart of system model

Load switching pattern is defined for each load and inverter power tracking algorithm is modeled by inside the Matlab function block. Related flow chart of the implemented algorithm is show in figure 10.

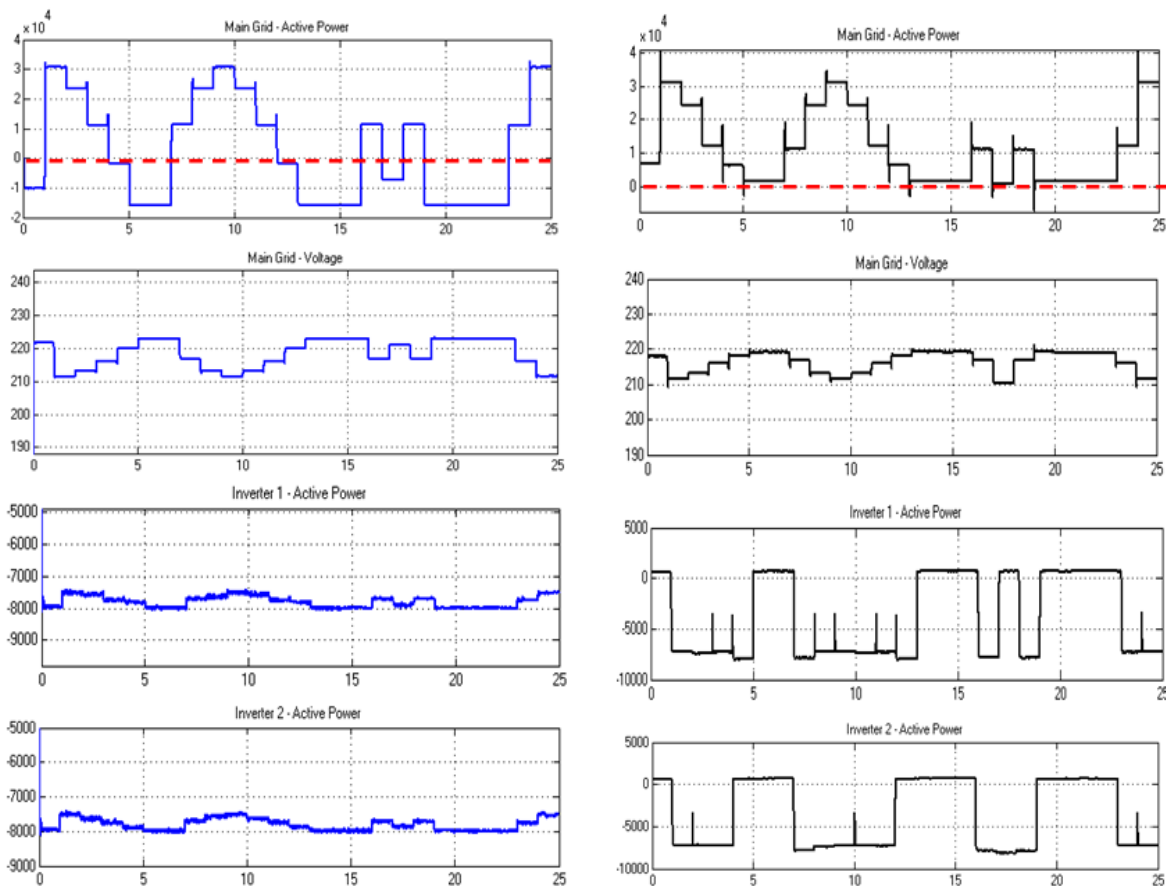

Figure. 11. Feeder profile without power tracking scheme

The power tracking algorithm according to the flowchart system was constructed Matlab function to follow required power delivery to the system. Without power tracking algorithm if inverters are operating all day, we observe reverse power flow between 5-7 seconds, 13-15 seconds and 19-22 seconds where no load demand. 13-15 seconds are important since the solar generation is highly active during these hours. In the simulation 1 second is referred as 1 hour of the day.

Figure 11 shows feeder profile including main grid power, voltage and injected power from inverter based distributed generators. Although global load feeding is allowed to the generator, when there is no load demand inside the transformer area, inverters still injecting power to the grid. This situation cause reverse power flow from LV to MV side. The power tracking scheme is implemented and results can be seen in figure 12. Proposed algorithm successfully eliminates reverse power flow when local load and global load do not exist in the system. In that case, inverter will continue to charge battery or cease generation.

5. CONCLUSION

In this project, utility connection of PV based distributed generator in low voltage feeders was proposed. An important concern about the penetration level of distributed resources is investigated. A proper model with an energy management algorithm for diverse load patterns considering reverse power flow control. Proposed algorithm and connection properties of distributed resource were tested in simulation environment. The simulation result shows reverse power flow control can be controlled by proper implementation of distributed resources by means of power rate and operation modes.

REFERENCES

- [1] IEEE Application Guide for IEEE std 1547™, IEEE Standard for Interconnecting Distributed Resources with Electric Power Systems
- [2] Hiroyuki Hatta, Satoshi Uemura, and Hiromu Kobayashi, " Cooperative Control of Distribution System with Customer Equipments to Reduce Reverse Power Flow from Distributed Generation," in Power and Energy Society General Meeting, 2010 IEEE , July 2010
- [3] Asari, M. ; Kobayashi, H., " Method of controlling reverse power flow of PV system with heat pump water heater," in Innovative Smart Grid Technologies (ISGT Europe), 2012 3rd IEEE PES International Conference and Exhibition on , October 2012
- [4] Inoue, K. , Iwafune, Y., " Operation of heat pump water heaters for restriction of photovoltaic reverse power flow," in Power System Technology (POWERCON) 2010 International Conference on, October 2010
- [5] Hatta, H. , Asari, M., Kobayashi, H." Study of energy management for decreasing reverse power flow from photovoltaic power systems," in Sustainable Alternative Energy (SAE), 2009 IEEE PES/IAS Conference on, September 2009
- [6] Load profiles. Retrieved April 30, 2010, from <http://www.akedas.com>

Authorization and Disclaimer

Authors authorize LACCEI to publish the paper in the conference proceedings. Neither LACCEI nor the editors are responsible either for the content or for the implications of what is expressed in the paper.